

modern  
HOME

# GRILL OGRODOWY GARDEN GRILL

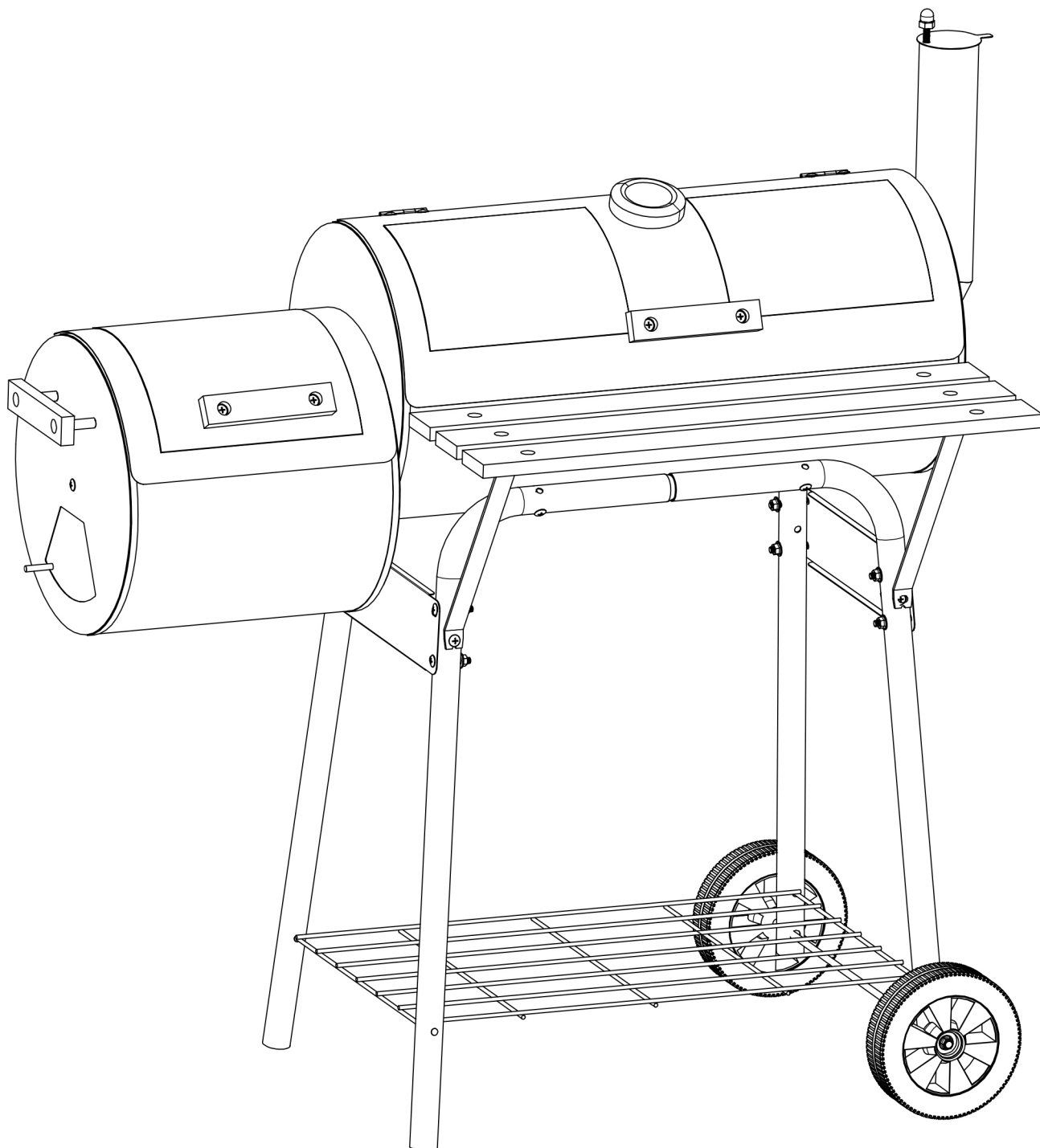

## INSTRUKCJA MONTAŻU ASSEMBLY MANUAL

# SAFETY INFORMATION













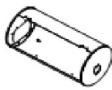

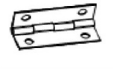









## WARNING













- Outdoor use only. DO NOT use the grill indoors or in an enclosed or non-ventilated area.
- Keep a fire extinguisher near this product at all times.
- For household use only. DO NOT operate this grill for other than its intended use.
- Some parts of this grill have been re-oiled at the factory. Please burn off the oils before cooking
- Do not wear loose clothing when using the grill or allow hair to come in contact with the grill.
- Never use the grill on a wooden surface or other flammable surfaces. Use the grill only on a hard, stable surface that can support the grill weight.
- Keep 10 feet of clearance between grill and any combustible materials when grill is in use (including, but not limited to bushes, shrubs, trees, leaves, grass, wooden decks or fences, buildings, etc. )
- Keep the grill away from gasoline and/ or other flammable liquids, gases, vapors, or areas where these may be present. Do not store or use the grill in these areas.
- In windy conditions, place it in an outdoor area that is sheltered from the wind.
- Keep out of the reach of children and pets, store out of the reach of children when not in use.
- When moving or lifting the grill, use it cautiously to avoid back strains or injuries.
- Do not try to move the grill while it is in use.
- Don't place goods over 10kgs/22lbs on each side shelf. Do not use gasoline, kerosene, or alcohol to light charcoal. Using any of these products or similar products could cause a flare up, a flash fire or an explosion. Severe bodily injuries can be a potential result.
- If using a lighter fluid to start a fire, leave the roll top hood open until briquettes area has shed over and lighter fluid has burned off. Closing the hood too soon could cause fumes from the lighter fluid to accumulate inside the grill. This could cause a flare up or an explosion when the hood is opened.
- Do not add a lighter fluid to warm or hot coals. A flash fire may result that could cause bodily injuries.
- Do not add instant light charcoal briquettes to the existing fire. A flash fire may result that could cause bodily injuries.
- Do not light and operate the grill without the slide out ash pan in place.
- Do not leave grill or coals hot and ashes unattended.
- Do not remove or empty slide out ash pan until coals and ashes have completely cooled.
- Allow the unit to cool completely before conducting any routine cleaning or maintaining.
- "WARNING! This barbecue will become very hot, do not move it during operation""Do not use indoors!"
- "WARNING! Do not use spirit or petrol for lighting or re-lighting! Use only firelighters complying to EN1860-3!"

# Wskazówki dotyczące bezpieczeństwa

- Należy zachować ostrożność na potencjalnie ostre krawędzie przy montażu.
- Upewnij się, że wszystkie części są mocno zmontowane.
- Upewnij się, że produkt stoi równo na płaskiej, niepalnej powierzchni.
- Trzymaj produkt z dala od łatwopalnych przedmiotów.
- Grill może być użytkowany tylko przez kompetentne osoby dorosłe. Uważać na dzieci i zwierzęta domowe.
- Nigdy nie używać spirytusu, parafiny, benzyny lub innych lotnych, łatwopalnych płynów do rozpalania. Dla lepszego rozpalenia używać tylko specjalnych podpałek zgodnie z instrukcją podaną przez producenta. Nigdy nie dodawać podpałki po rozpaleniu węgla drzewnego.
- Należy zachować szczególną ostrożność przy metalowych częściach grilla, które mogą być gorące. Podczas użytkowania grilla lub przewracania używać rękawicy ochronnej.
- Gorący tłuszcz spadający na węgiel może spowodować wzniesienie płomienia. Aby go zmniejszyć i zapobiec spaleniui jedzenia, węgiel należy delikatnie skropić wodą.
- Po zakończonym grilowaniu, węgiel należy dogasić skrapiając go wodą lub zasypując piaskiem.
- Zawsze należy upewnić się, że grill jest całkowicie zimny przed jego przesunięciem lub usunięciem popiołu.
- **GRILL NIGDY NIE MOŻE BYĆ UŻYTKOWANY W POMIESZCZENIACH ZAMKNIĘTYCH. UŻYWAĆ TYLKO NA WOLNEJ PRZESTRZENI.**
- Należy chronić produkt przed działaniem niesprzyjających warunków atmosferycznych (deszcz, mróz, wigoł, silne podmuchy wiatru, itp.) Produkt należy przechowywać w miejscu zadaszonym, nienarażonym na działanie promieni słonecznych.
- W okresie zimowym zaleca się rozmontowanie produktu i przechowywanie w miejscu nienarażonym na warunki atmosferyczne.
- Czyść produkt lekko zwilżoną ściereczką i łagodnym detergentem. Nie używaj agresywnych chemikaliów.

# Part List

NO.	Pic.	Spe	QTY	NO.	Pic.	Spe	QTY
1		main body	1pc	13		wheel	2pcs
2		fire box	1pc	14		hinge	4pcs
3		air door	1pc	15		bracket	2pcs
4		front table bracket	2pcs	16		wood plate	3pcs
5		chimney cap	1pc	17		thermometer	1pc
6		front left leg	1pc	18		handle	3pcs
7		front right leg	1pc	19		charcoal grid	3pcs
8		bottom rack	1pc	20		cooking grid	2pcs
9		side plate	2pcs	21		wheel axle	1pc
10		fire box lid	1pc	22		main lid	1pc
11		handle spacer	6pcs	23		back left leg	1pc
12		chimney	1pc	24		back right leg	1pc

NO.	Pic.	Spe	QTY	NO.	Pic.	Spe	QTY
A		M6*12 screw	13pcs	B		M8 nut	2pcs
C		M6*35 screw	12pcs	D		M5 nut	6pcs
E		M5*15 screw	6pcs	F		M6 nut	35pcs
G		M4*10 screw	16pcs	H		spring	1pc
I		M6*45 screw	8pcs	J		chimney cap	1pc
K		butterfly nut	1pc	L		M4 nut	16pcs

# ASSEMBLE

## Step 1

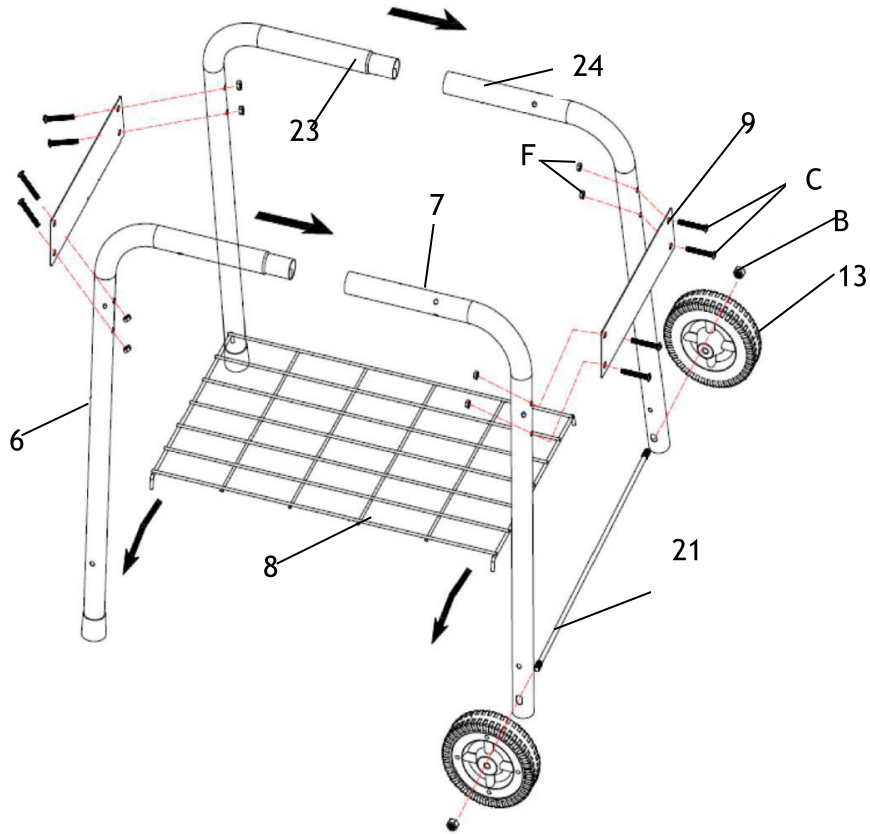

## Step 2

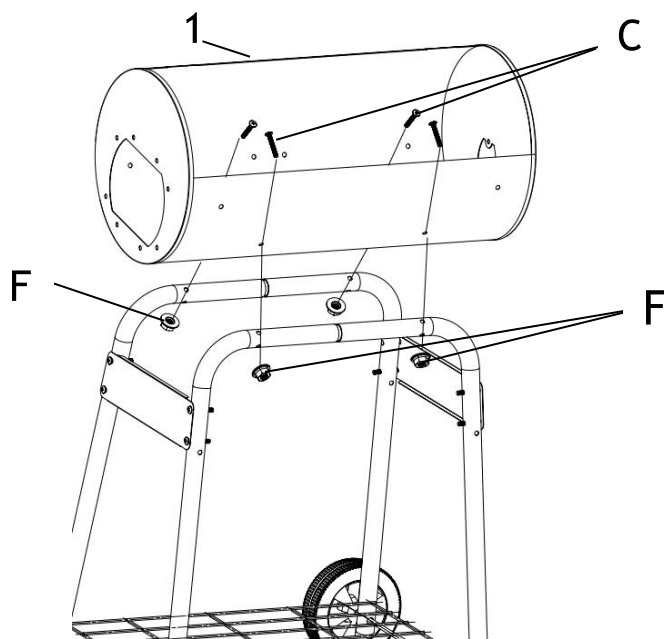

Step 3

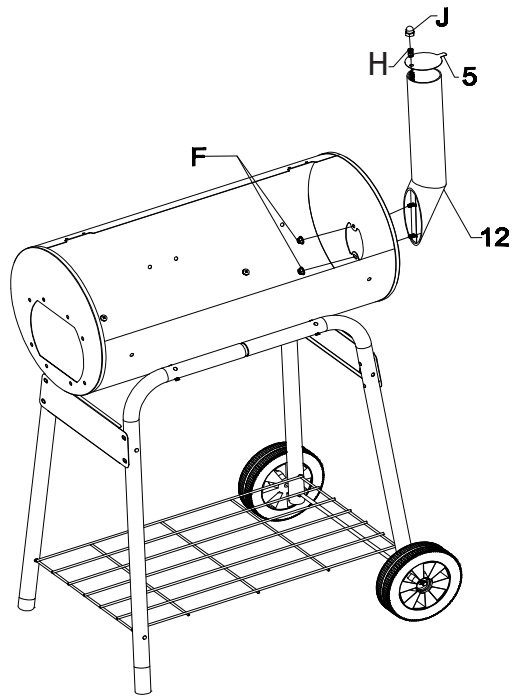

Step 4

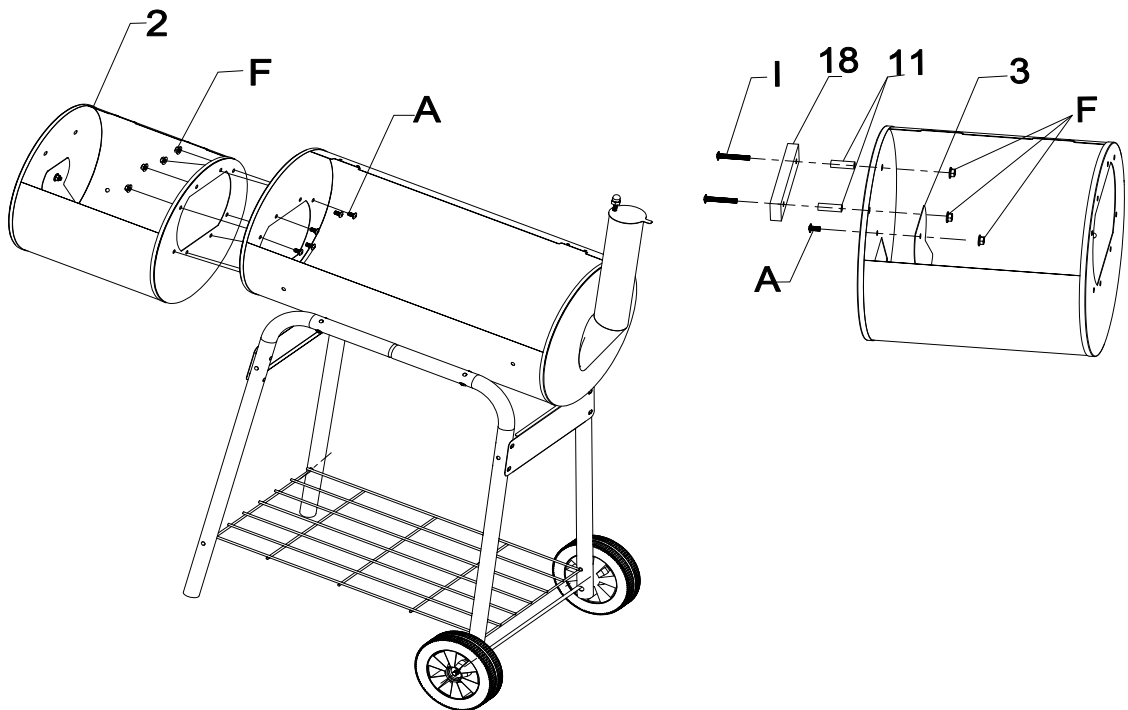

Step 5

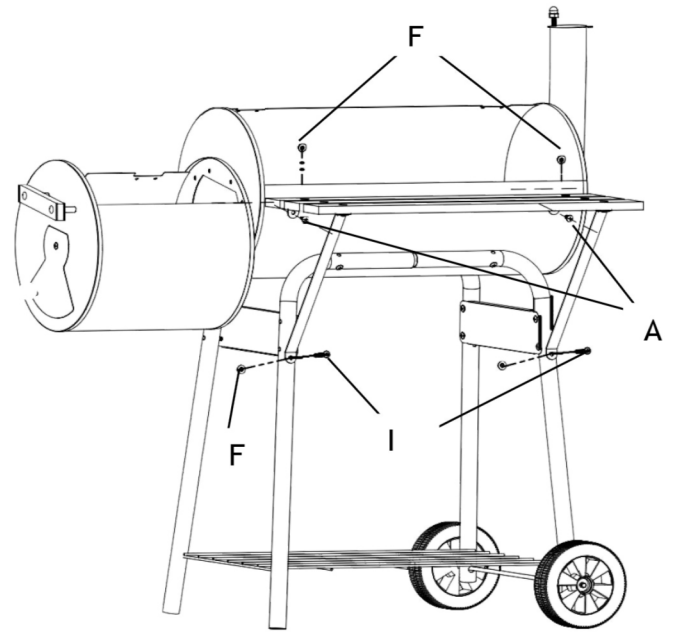
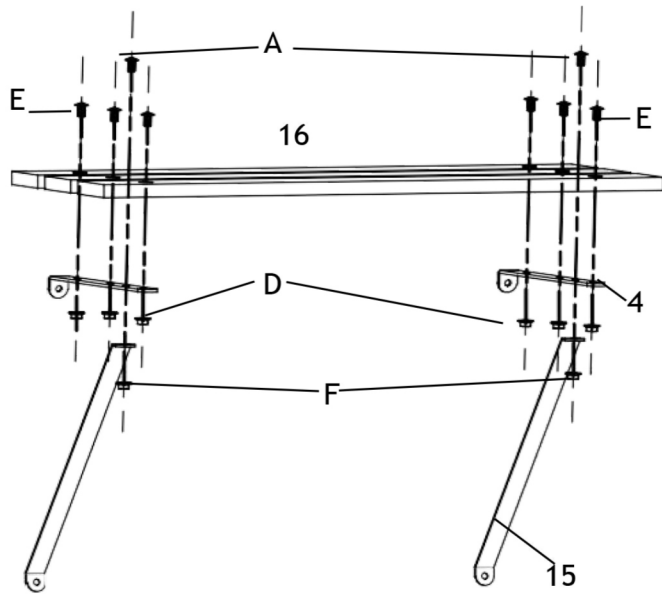

Step 6

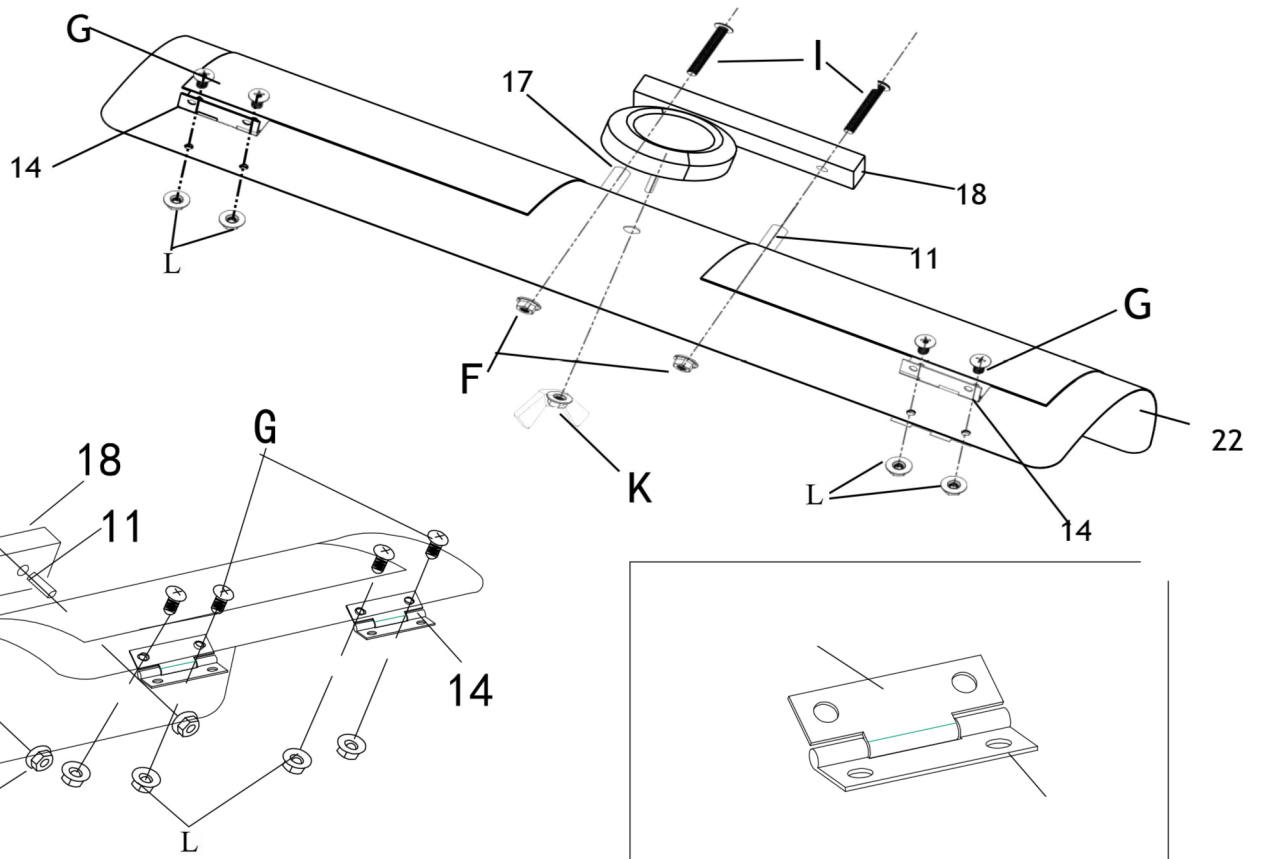

Step 7

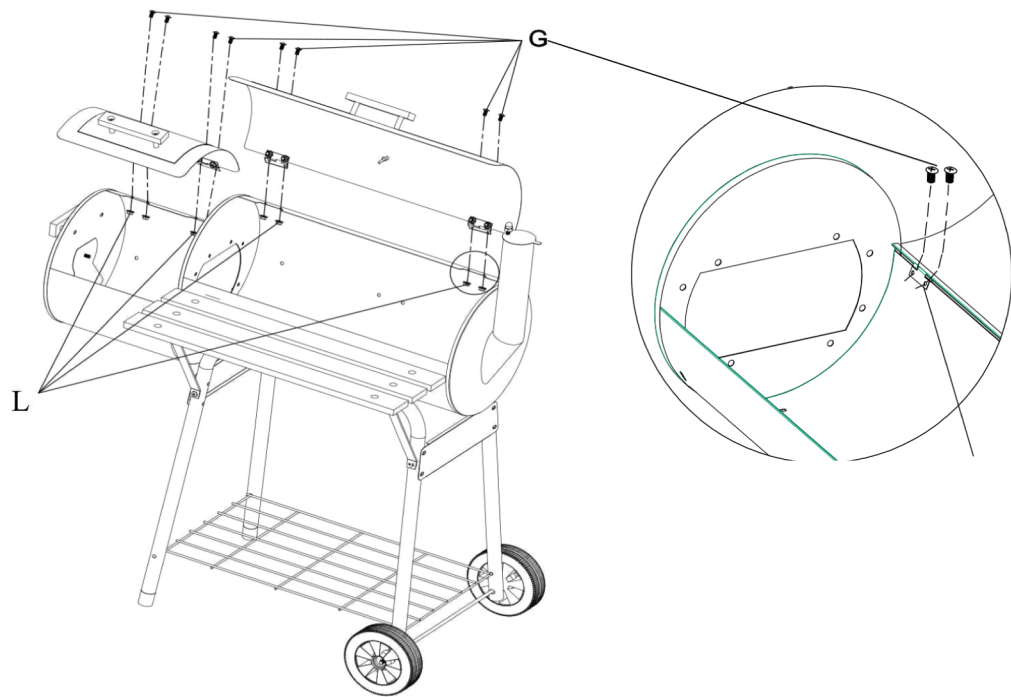

Step 8

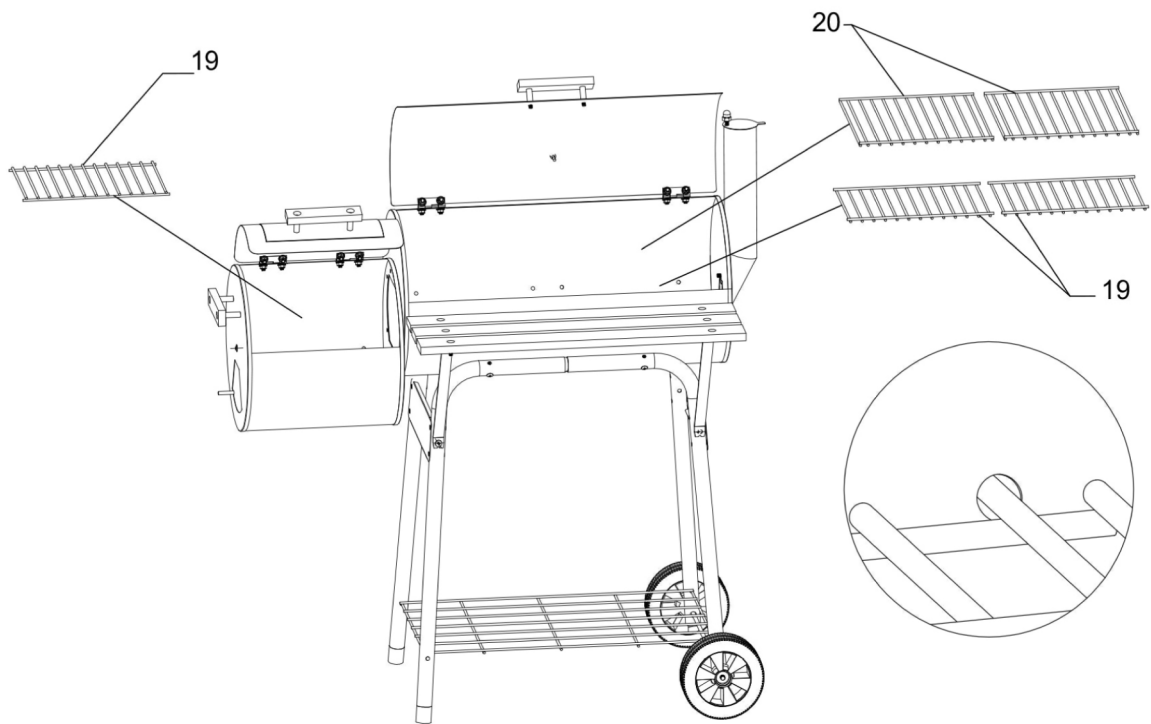



Step 9

